

### THE CWP RO HOT WATER HEATER TROUBLESHOOTING

When troubleshooting the CWP RO heater, it is important to diagnose the exact mode of failure as described in this technote so the correct replacement parts can be ordered.

#### REPLACEMENT PARTS



- W3T577811 KIT,REPLT,HEATER,CWP,8KW,208V,3PH
- W3T577679 KIT,REPLT,HIGH LIMIT SWITCH,CWP HEATER

#### TROUBLESHOOTING PROCEDURE:



The CWP RO heater requires 208 VAC. To avoid shock/serious injury, always remove power to the CWP RO before handling high voltage components.

#### 1. Verify power to heater

Put the CWP RO in high temperature mode. Press , scroll down to Technician info and press . Scroll down to “Man high temp HW”, scroll curser over “no” and press .

Verify the heater relay is “pulled in”. Verify 208VAC between terminals 1-2, 1-3, 2-3 on the High Limit Switch, see figures below. If measured voltage is not 208VAC  $\pm 5\%$ , consult an electrician. Turn off high temperature mode.

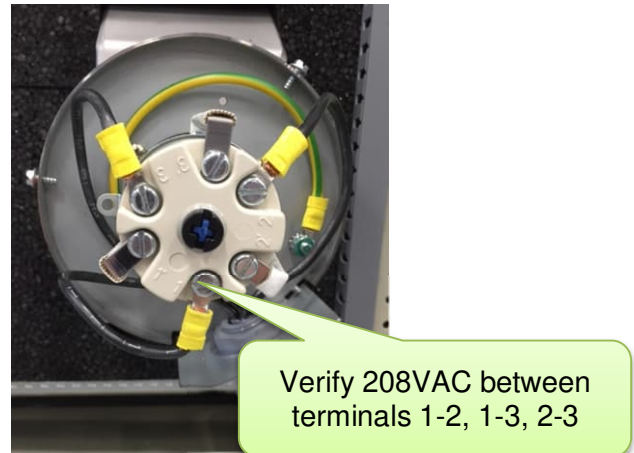
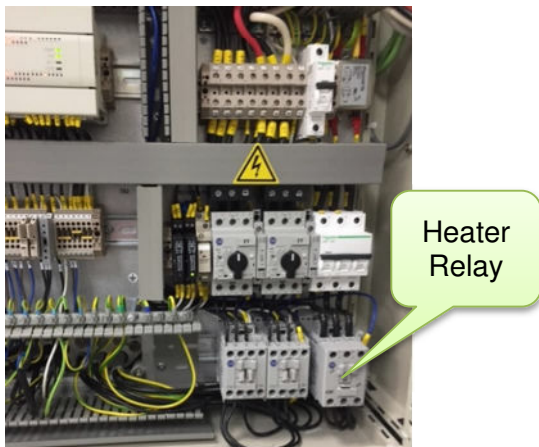

### 2. Verify functionality of the CWP RO heater

Using an ohmmeter, verify continuity through each of the 3 heater elements. A quick method to verify continuity is to measure the resistance between jumpered pairs, circled in the figure below. The resistance between each jumpered pair should be  $\sim 10\text{-}12 \Omega$ . If a heating element has failed, order kit W3T577811.

Note: The High Limit Switch has been removed for better visualization.

Note: This continuity check does not isolate and measure resistance across individual heating elements. To double check a failed heating element, remove the jumpers and then check resistances. Per specification resistance of each heating element should be  $15.9 \Omega \pm 10\text{-}5\%$ .

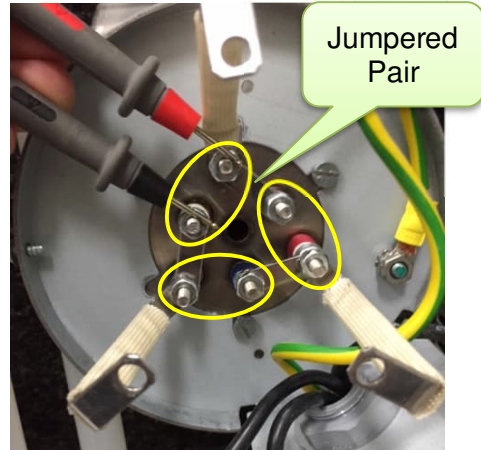

- Resistance  $\sim 10\text{-}12 \Omega$  at each of the 3 measurement points means that the heating elements are functional and the root cause of the failure is likely the High Limit Switch.
- If one of the elements has failed the resistance will measure  $\sim 15.5 \Omega$  across two of the jumpered pairs and  $\sim 30 \Omega$  across the remaining jumpered pair. If two elements have failed the resistance will be infinite across two of the jumpered pairs and  $\sim 15.5 \Omega$  across the remaining jumpered pair. If all of the elements have failed, resistance will be infinite across all jumpered pairs.

### 3. Verify functionality of the High Limit Switch

Inspect the epoxy securing the black “set plug” to the High Limit Switch’s ceramic housing, refer to the figures below and High Limit Switch Epoxy Failure Detail at the end of this document for details. If the epoxy has released from the housing, order kit W3T577679.

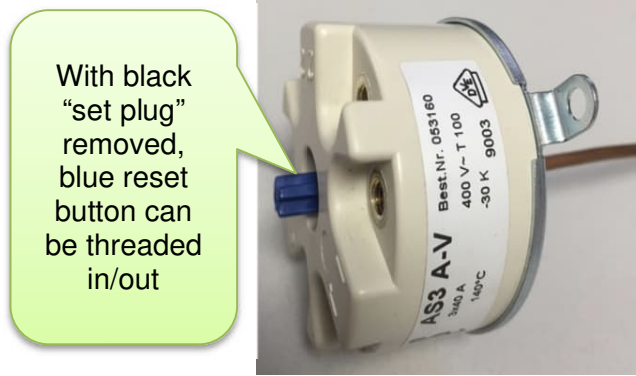

Confirm a white insulating sleeve is not present on the copper probe of the High Limit Switch. If one is present, remove and discard as it is not necessarily and may retain heat, refer to the figure below.

If white insulating sleeve is present, remove and discard



Check if the High Limit Switch has “tripped”; the blue reset button would be extending 1.7 mm past the black “set plug”. The High Limit Switch should not “trip” during normal heat disinfection if it is within tolerance. Reset the High Limit Switch if it has tripped. If the problem persists order a replacement switch, W3T577679.

Verify the resistance across terminals 1'-1, 2'-2, 3'-3 on the High Limit Switch is  $< 2 \Omega$ . If the switch has been reset and there is still no continuity, order a replacement switch, W3T577679.

#### 4. Verify functionality of CWP RO temperature control circuit

The CWP RO heater is controlled by temperature sensor 92. Water in the HW Tank will be under/over target temperature if sensor 92 is out of calibration. Heat disinfection is monitored with product water return temperature sensor 56. Refer to the CWP Service Manual, section 3.3.4 (Temperature Circuit) and 3.3.5 (System Return Temperature) for steps to check the temperature control circuit.

If calibration is deemed necessary, refer to section 3.4.11 (Adjusting Temperature Circuit) in the CWP Service Manual.

Additional information is included in the CWP Service Manual on troubleshooting temperature sensors 92 and 56, Temperature Transmitter TX200, and the PLC. Refer to section 2.6.4 (Temperature Transmitter TX200), and Corrective Action steps in section 6.2.10, 6.2.26 and 6.2.27.

### High Limit Switch Epoxy Failure Detail

A bad epoxy seal on the CWP RO heater's High Limit Switch can present as a heater failure. The manufacturer is now using an improved epoxy process starting with heater lot number 1340332. The reset button is held in position by a "set plug" which is the component directly epoxied to the High Limit Switch's ceramic housing. If the epoxy fails, the "set plug" no longer secures the reset button, see figures on pg 3.

The blue reset button has a threaded connection at switch assembly. If the reset button is turned clockwise after an epoxy failure, it is forced against the diaphragm of the thermal probe in the switch assembly. This then pushes the switch contacts apart and opens the heater circuit as if the High Limit Switch has tripped.

