

REVISED MCB DUAL TANK MIX & DELIVERY BICARB SYSTEM DISINFECTION PROCEDURE

Introduction:

This procedure is intended to improve the disinfection process of the entire bicarb mix and delivery system with added attention to the main inlet water feed line, primarily when hot water loop disinfection has been incorporated into the dialysis water distribution system. It is used on the MCB 212 model, either 100-gallon and/or 50-gallon systems. This procedure is intended to replace the existing one as stated in the latest revision of the Operating and Maintenance Manual, P/N W3T573917, section 5.3 and 5.4.

Parts Required:

Kit (P/N: W3T578125)

This kit includes the necessary part, fittings, and instructions to update your current MCB 212 model plumbing ports. This allows you to connect the MCB Inlet Product Water line to the Bicarbonate Distribution Loop Return line in order to disinfect the complete system when used with a heat disinfect RO water distribution loop. This kit should be installed just prior to a scheduled disinfection procedure of your MCB 212 unit.

Procedure:

Use the following STEPS to perform a Bicarb system disinfection and disinfectant rinsing procedure of the MCB Dual Tank unit including the bicarbonate distribution piping system.

MCB 212 - Bicarb Flow Diagram

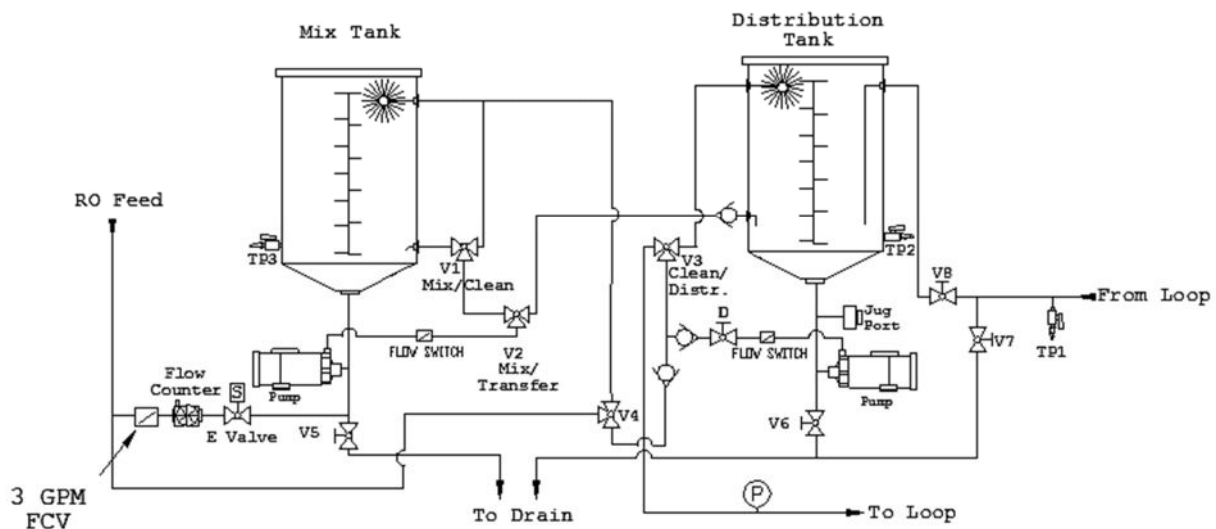

Figure 1: MCB 212 Flow Schematic

Minnicare is a trademark of Medivators, Inc and its affiliates.

1. Verify the inlet RO water valve is open.
2. Turn off valves **V1**, **V2**, **V3**, and **V4**.
3. Close **Mix Tank** drain valve **V5**, **Distribution Tank** drain valve **V6**. Close **Return Loop** valve **V8** and open **Bicarb Loop** drain valve **V7**.

WARNING: Wear gloves, eye protection and protective clothing as required by the SDS.

4. Add 2000 cc of Minncare® HD Disinfectant or bleach to the **Distribution Tank**.

WARNING: Place a label on the Bicarb system stating “WARNING: DO NOT USE”.

5. Turn valve **V3** to **Dist. Clean** and valve **V4** to **Loop Rinse**, then fill to 189 liters (50 gallons).
6. Turn **V3** and **V4** off.
7. Turn **V3** to **Distribution Return** and start **Distribution Pump**, if not already started.
8. Continue to send the disinfectant solution through the drain through **V7**, until there is a positive result at **TP1** and **TP2**. Use the appropriate indicator test strips. Throttle Valve **V7** to allow flow through **TP1**.
9. When **TP1** and **TP2** are positive for the disinfectant, Open **Return Loop** valve **V8** and close **Bicarb Loop Drain** valve **V7**.
10. Close the inlet water valve and, if applicable, turn off the Over Temp. Solenoid Valve Switch. Disconnect the **Inlet Product Water Hose** from the **RO Distribution Loop** feed and disconnect **Bicarbonate Distribution Loop Return** on the right side of the MCB from its fitting. Connect the **Inlet Product Water Hose** to the **Bicarbonate Distribution Loop Return** connection.

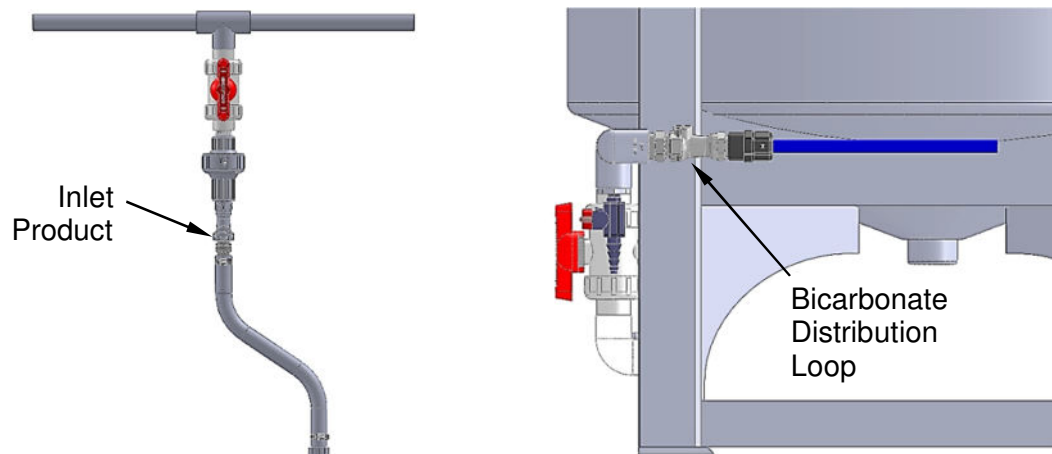

Figure 2: Inlet Produce Water Hose and Bicarbonate Distribution Loop Return

MCB 212 - Feed Line Disinfection

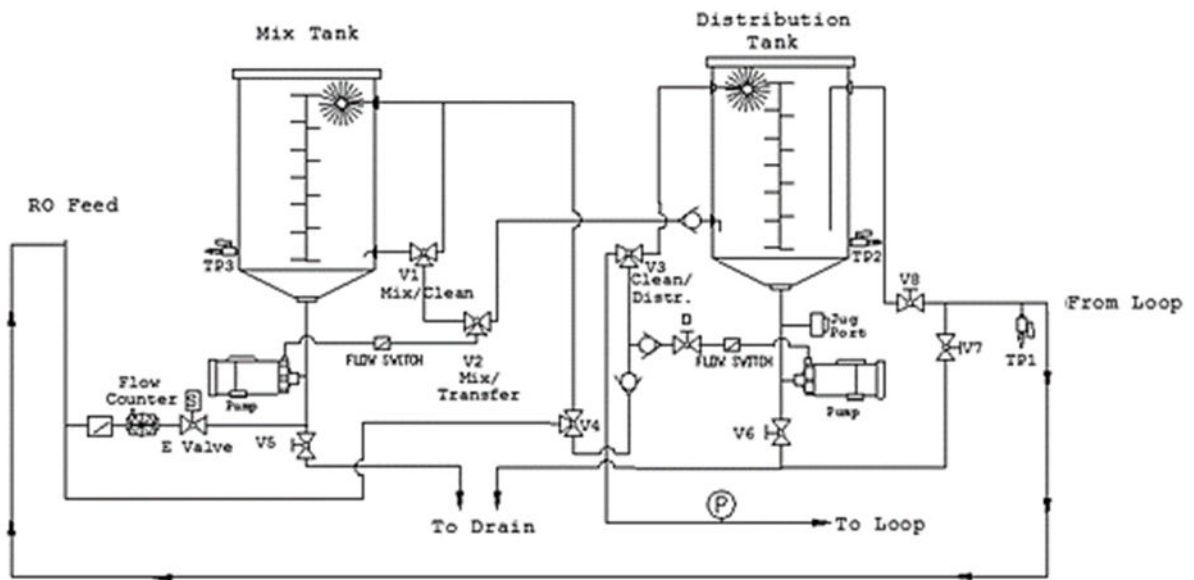

Figure 3: MCB 212 Disinfection Flow Schematic

11. On the **Batch Meter**, press the **RST** button to zero out the meter.
12. On the **Batch Meter**, press the **PAR** button once, the screen flashes **SP 1** (this is the Set Point Low) and adjust to 95 liters (25 gallons). Then press the **PAR** button once again. If necessary, press **RST** to toggle through the numeric display. Press the **UP** and **DOWN** arrows to adjust accordingly.
13. Once **SP 2** is flashing, press the **PAR** button once again. **END** will be displayed and your settings loaded.
14. Press the **Mix Tank Fill Control** **START** button, then close the **Return Loop** valve **V8** to fill the tank to the **SP 1** level. (Note: Button light does not illuminate during this fill. Solenoid Fill Valve will shut off when volume is attained in the tank). If distribution pump is not running, press and hold the distribution pump start button until the LED illuminates.
15. While the **Mix Tank** is filling, insert the quick disconnect end of the jug filling hose into the **Jug Port** at the base of the **Distribution Tank** and drain approximately 4 liters (1 gallon) of solution into a bucket. Drain and test for the presence of disinfectant with the appropriate test strip.
16. While the **Distribution Tank** is recirculating and the **Mix Tank** is filling, test ALL points-of-use for the presence of the disinfectant solution using the appropriate test strip. (Note: **Mix Tank** should be close to completing the **SP 1** fill cycle).

17. After the **Mix Tank** fills to the **SP 1** set point, press the meter's **RST** button.
18. Turn **V1** to **Mix** and **V2** to **Mix/Clean**.
19. Press the **Mix-Transfer Pump** START button (hold button for 5-10 seconds). The disinfectant solution in the **Mix Tank** will begin to circulate.
20. Mix for approximately 2 minutes and then test solution for the presence of disinfectant through **TP3** using the appropriate test strip.

Note: If the pump shuts off, restart it accordingly.

21. When the disinfectant mixture is confirmed, turn **V1** to **Clean** and press the **Mix Transfer Pump** start button to circulate the solution through the spray nozzle for approximately 5 minutes. If the mixture is not correct, add more water or disinfectant accordingly and retest.
22. Turn **V3** to the **Dist. Clean** position and start the **Distribution Pump** if not already started, operate for approximately 2 minutes, then turn **V3** to **Off**.
23. Turn **V4** to **Mix Tank Rinse** for 2 minutes and then turn **V4** to **Loop Rinse** for another 2 minutes. Turn **V4** to **Off**.
24. Open valve **TP3** to disinfect the **Mix Tank Test Valve**, draining approximately 4 liters (1 gallon) into a bucket. Confirm presence of disinfectant using the appropriate test strip. Once confirmed, close **TP3**.
25. Press the **Mix-Transfer Pump** STOP button (hold for 5-10 seconds) to turn off the pump.
26. Turn **V1** to **Off** and **V2** to **Transfer**. The pump may start automatically. If not, press the **Mix-Transfer Pump** START button (hold for 5-10 seconds) and transfer all of the disinfectant solution into the **Distribution Tank**.
27. Press the **Distribution Pump** STOP button to turn off the pump.
28. Place valves **V1**, **V2**, **V3** and **V4** in the **Off** position.

Note: The system is now dwelling in a disinfectant solution. The recommended total contact time is one (1) hour. Contact time begins at the time the disinfecting solution was introduced into the system. After the recommended time, proceed to STEP 29.

Bicarb System Disinfectant Rinse:

29. Open valves **V5**, **V6** and **V7** to drain the disinfecting solution from both tanks and the loop and leave in the open position.
30. Disconnect the **Inlet Product Water Hose** from the **Bicarbonate Distribution Loop Return** Hose. Reconnect the **Inlet Product Water Hose** to the **RO Distribution Loop** and the **Bicarbonate Distribution Loop** to the **Bicarbonate Distribution Loop Return** connection on the right side of the MCB.

Note: The Bicarb system is equipped with an RO water 'fast rinse' feature for the Mix Tank and the loop.

31. Turn **V4** to **Mix Tank Rinse** and then open the **Inlet Product Water Valve**. If applicable, switch on the Over Temp. Solenoid Valve controller.

Note: This will ensure a positive water flow to the Bicarb Mixer and prevent any possible disinfectant rebound in the RO piping distribution loop.

32. After approximately 3 minutes, turn **V4** to **Off** and allow the solution that has accumulated inside the Mix Tank to completely drain. Once drained, turn **V4** to **Mix Tank Rinse** for approximately 2 minutes, testing at the drain until a negative result is achieved by confirming with the appropriate test strip. Once negative, turn **V4** to **Off**.
33. Press the **Par** Button once on the Batch Meter. The screen will flash **SP 1**. Adjust to 25 liters (7 gallons).
34. Press the **Par** Button again. The screen is now flashing **SP 2**. Press the **Par** Button again. Your settings are now loaded. Close valve **V5** and **V6**.
35. Press the **Mix Tank Fill Control Start** Button. The water will fill to the **SP1** level.
36. Once **SP 1** level is reached, press the meter **RST** button. Open valve **V5**.
37. Check the drain flow for residual disinfectant. Repeat STEPS 31 – 36 until negative at the drain. Confirm with the appropriate test strip.
38. Once a negative result is achieved, close **V5** and then open **V4** to **Mix Tank Rinse** to allow 95 liters (25 gallons) to fill in the Mix tank. Once achieved, turn **V4** to **Off**.
39. Turn **V1** to **Mix** position and **V2** to **Mix/Clean** position.
40. Press **Mix-Transfer Pump** START button (hold until light illuminates) and circulate for 2 minutes then turn **V1** to **Clean** for an additional 2 minutes.
41. Press the **Mix Transfer Pump** STOP button. Turn **V1** to **Off** and **V2** to **Transfer**. Press **Mix-Transfer Pump** START button to transfer the water. (Pump will stop automatically). While transferring, test for residual at **TP3**. Confirm with the appropriate test strip.

42. If positive, drain the tank and repeat STEPS 38-41. If negative, proceed to the next step.
43. Turn **V4** to **Loop Rinse** and **V3** to **Dist. Return**. Open **Return Loop Valve V8** and close **Bicarb Loop Drain Valve V7**. Rinse the loop through the **Distribution Tank** until a negative result is achieved at **TP1**. Confirm with the appropriate test strip.

Note: This step is time proportional to Bicarb loop distance.

44. Test **all points of use** for absence of disinfectant. Continue to rinse until **all points-of-use** are negative. Confirm with the appropriate test strip.
45. Turn **V3** to **Dist. Clean** and rinse for approximately 5 minutes. While rinsing, open drain valve **V6**. Test at the **Distribution Tank** drain to verify a negative result. Verify with the appropriate test strip.
46. Once 5 minutes has elapsed and the **Distribution Tank** is completely empty, turn **V3** and **V4** to **Off**, close valve **V6**, close valve **V8**, and open valve **V7**.
47. Turn **V3** to **Dist. Clean** and **V4** to **Loop Rinse** to allow 95 liters (25 gallons) to fill the **Distribution Tank**.
48. Once completed, turn **V3** and **V4** to **Off**. Connect the quick disconnect fitting at the **Jug Fill Port** and run to drain. After 19 liters (5 gallons) have drained, test for a negative result. Confirm with the appropriate test strip. If positive, drain the tank and repeat STEPS 45-47. If negative, proceed to the next step.
49. Turn **V3** to **Dist. Return** and press the **Distribution Pump** START button to distribute water in the **Distribution Tank** to drain through **V7**.
50. Test for residual disinfectant at **TP1** and **TP2**. Wait for a bolus of disinfectant solution to appear at Drain and **TP1** and continue to rinse until negative, approximately 30 liters (8 gallons). Confirm with the appropriate test strip.

Note: It may be necessary to throttle valve **V7** to obtain flow through **TP1**.

51. If positive when the tank is nearly empty, repeat STEPS 46-49 until a negative result is achieved.

Note: If desired, press the MUTE button to bypass the low tank alarm.

52. With the **Distribution Pump** off and after the tank is empty, turn valve **V3** to **Off**. If required, press the mute button again to restore the low-level alarm.
53. Open **V8** and close **V7**.
54. If not already completed, open **V5**.
55. Record date, time, and operator's initials on the log sheet and remove all **WARNING** labels.

Note: The system has been disinfected and thoroughly rinsed. The unit is now ready for normal operation.

Note: The following steps allow the user to add water to the Distribution Tank so that water can be circulated through the bicarb loop during non-dialyzing periods as a potential way to maintain loop integrity.

56. Turn **V3** to **Dist. Clean** and **V4** to **Loop Rinse**. Fill **Distribution Tank** to 95 liters (25 gallons).
57. Turn **V3** to **Dist. Return** and verify **V1**, **V2** and **V4** are off.
58. Press and hold the **Distribution Pump** start button if the pump doesn't start automatically to begin circulating water through the bicarb loop.

WARNING: If the disinfection procedure was initiated prior to a new batch of bicarbonate being made, a residual test should be performed prior to the start of the mixing cycle. (Note: See the Bicarb Rinse Procedure).

Please be sure to contact Technical Support at 888-595-0666 if you have any questions or require further assistance.